



171D/170D Ultra Low Differential Pressure Switch



Made in USA

FEATURES / BENEFITS

- Rugged design for use in harsh environments
- Pressure ranges from 0.05”–40” H₂O (0.12–100 mbar)
- Shock and vibration resistance (MIL-S-901-D & MIL-STD-167-1)
- Chemical resistant epoxy finish available
- Suitable for high voltage/current applications

SPECIFICATIONS

MECHANICAL

Set Point Ranges	0.05”–40” H ₂ O (see below) (0.12–100 mbar)
Dead Band	Consult Factory
Proof Pressure	Up to 25 psi (dependant on model) Up to 1724 mbar
Mechanical Life	1,000,000 Cycles
Temperature Range	-30–160° F (-34–71°C)

PHYSICAL

Housing Material	Zinc Die Cast, Aluminum Electrical Box
Diaphragm	0.008” Nitrile/Nylon Cloth (model 170) or 0.005” Silicone PE Cloth (model 171)
Pressure Port	1/8–27 NPT Female
Electrical Connection	Screw Terminals
Weight	2.510 lbs (1.14 kg)

ELECTRICAL

Switch Type	SPDT Snap Action
Current Rating	See Below

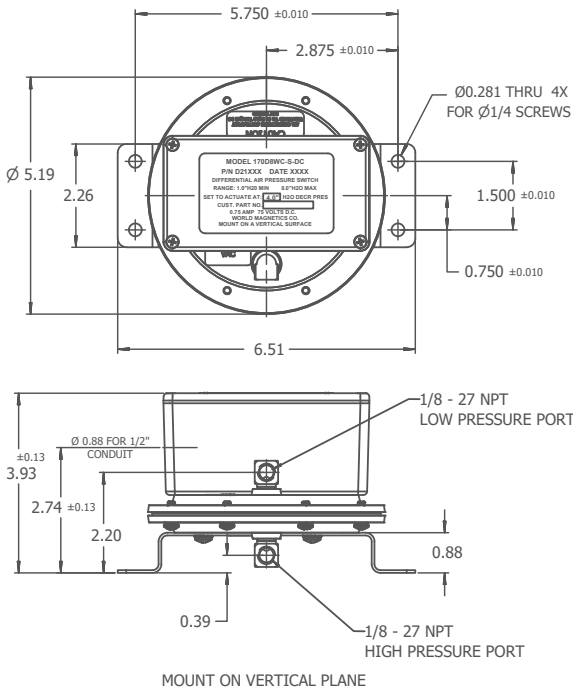

Model Number	Part Number	Operating Range	Deadband	Switch Current
--------------	-------------	-----------------	----------	----------------

170D8W-S	D21530	1.0–8.0” H ₂ O (2.5–20 mbar)	0.2–0.6” H ₂ O (0.5–1.5 mbar)	10 Amp 125 VAC
170D8W	D21531	2.0–8.0” H ₂ O (5.0–20 mbar)	0.3–0.8” H ₂ O (0.75–2.0 mbar)	15 Amp 125 VAC
170D20W	D21532	2.0–20” H ₂ O (5.0–50 mbar)	0.3–1.0” H ₂ O (0.75–2.5 mbar)	15 Amp 125 VAC
170D40W	D21533	2.0–40” H ₂ O (5.0–100 mbar)	0.3–1.0” H ₂ O (0.75–2.5 mbar)	15 Amp 125 VAC
171D8WC-S	D21540	0.05–8.0” H ₂ O (0.12–20 mbar)	0.03–0.3” H ₂ O (0.07–0.75 mbar)	10 Amp 125 VAC
171D8WC	D21541	0.15–8.0” H ₂ O (0.37–20 mbar)	0.05–0.3” H ₂ O (0.12–0.75 mbar)	15 Amp 125 VAC
170D8W-S-DC	D21564	1.0–8.0” H ₂ O (2.5–20 mbar)	0.3–0.6” H ₂ O (0.75–1.5 mbar)	0.75 Amp 75 VDC
170D8W-DC	D21536	2.0–8.0” H ₂ O (5.0–20 mbar)	0.3–1.0” H ₂ O (0.75–2.5 mbar)	0.75 Amp 75 VDC
170D20W-DC	D21537	2.0–20” H ₂ O (5.0–50 mbar)	0.3–1.0” H ₂ O (0.75–2.5 mbar)	0.75 Amp 75 VDC
170D40W-DC	D21538	2.0–40” H ₂ O (5.0–100 mbar)	0.8–1.0” H ₂ O (2.0–2.5 mbar)	0.75 Amp 75 VDC
171D8-WC5-DC	D21542	0.15–8.0” H ₂ O (0.37–20 mbar)	0.05–0.3” H ₂ O (0.12–0.75 mbar)	0.75 Amp 75 VDC